

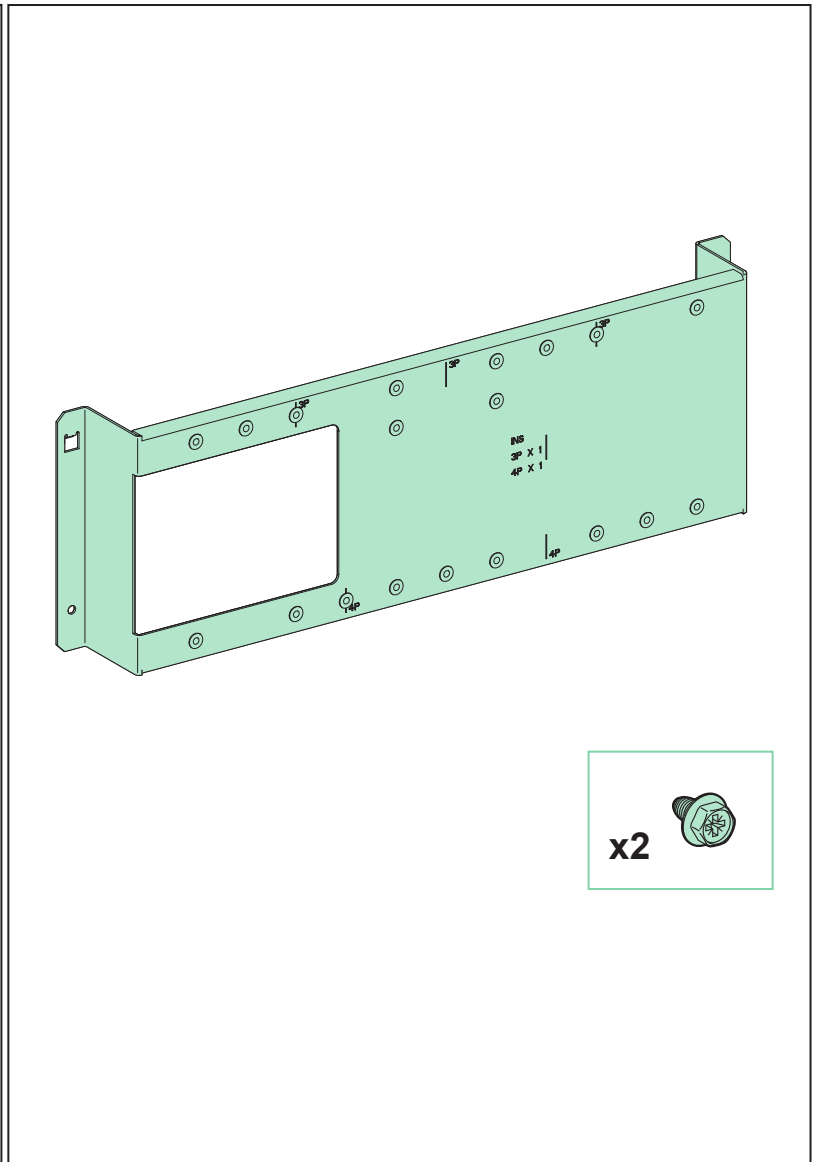

en fr es de it pt zh ru

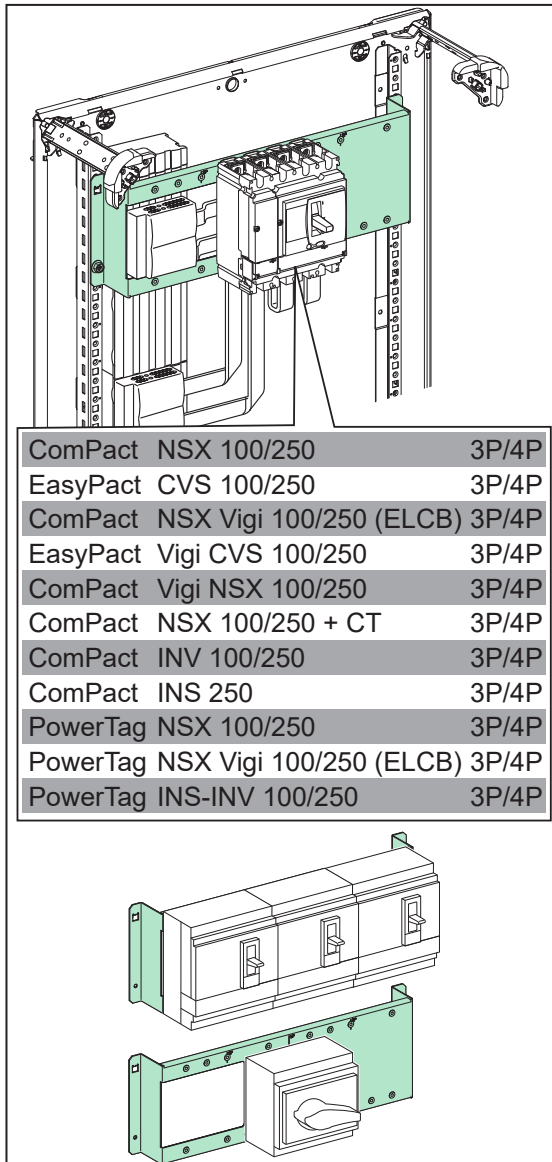

<p>PLEASE NOTE Electrical equipment should be installed, operated, serviced, and maintained only by qualified personnel. No responsibility is assumed by Schneider Electric for any consequences arising out of the use of this material.</p>	<p>REMARQUE IMPORTANTE L'installation, l'utilisation, la réparation et la maintenance des équipements électriques doivent être assurées par du personnel qualifié uniquement. Schneider Electric décline toute responsabilité quant aux conséquences de l'utilisation de ce matériel.</p>	<p>TENGA EN CUENTA La instalación, manejo, puesta en servicio y mantenimiento de equipos eléctricos deberán ser realizados sólo por personal cualificado. Schneider Electric no se hace responsable de ninguna de las consecuencias del uso de este material.</p>	<p>BITTE BEACHTEN Elektrische Geräte dürfen nur von Fachpersonal installiert, betrieben, bedient und gewartet werden. Schneider Electric haftet nicht für Schäden, die durch die Verwendung dieses Materials entstehen.</p>
<p>NOTA Manutenzione, riparazione, installazione e uso delle apparecchiature elettriche si devono affidare solo a personale qualificato. Schneider Electric non si assume alcuna responsabilità per qualsiasi conseguenza derivante dall'uso di questo materiale.</p>	<p>NOTA A instalação, utilização e manutenção do equipamento eléctrico devem ser efectuadas exclusivamente por pessoal qualificado. A Schneider Electric não assume qualquer responsabilidade pelas consequências resultantes da utilização deste material.</p>	<p>请注意 电气设备的安装、操作、维修和维护工作仅限于合格人员执行。Schneider Electric 不承担由于使用本资料所引起的任何后果”。</p>	<p>ОБРАТИТЕ ВНИМАНИЕ Установка, эксплуатация, ремонт и обслуживание электрического оборудования может выполняться только квалифицированными электриками. Компания Schneider Electric не несет никакой ответственности за любые возможные последствия использования данной документации.</p>

A

NSX 100/250
CVS 100/250
NSX Vigi 100/250 (ELCB)
Vigi CVS 100/250
Vigi NSX 100/250
NSX 100/250 + CT
PowerTag NSX 100/250
PowerTag NSX Vigi 100/250 (ELCB)

3P
4P

A'

NSX 100/250
CVS 100/250
NSX Vigi 100/250 (ELCB)
Vigi CVS 100/250
Vigi NSX 100/250
NSX 100/250 + CT
PowerTag NSX 100/250
PowerTag NSX Vigi 100/250 (ELCB)

4x3P
3x4P

A''

INS-INV 100/250
INS 250
PowerTag INS-INV 100/250 (ELCB)

3P/4P

B

m = 50 mm

1
2
3

4,4 N.m

LV429515 / LV429516 / LV429517 / LV429518
LVS04062
LVS04061

3P/4P		
NSX 100/160 CVS 100/160 NSX Vigi 100/160 (ELCB)		X = 167 m = 9m H = 450
NSX 250 CVS 250 NSX Vigi 250 (ELCB)		X = 267 m = 11m H = 550
Vigi CVS 100/160 Vigi NSX 100/160 NSX 100/160 + CT		X = 167 m = 10m H = 500
Vigi CVS 250 Vigi NSX 250 NSX 250 + CT		X = 267 m = 13m H = 650
INS-INV 100/250 INS 250		X = 117 m = 8m H = 400
PowerTag NSX 100/160 PowerTag NSX Vigi 100/160 (ELCB)		X = 167 m = 10m H = 500
PowerTag NSX 250 PowerTag NSX Vigi 250 (ELCB)		X = 267 m = 12m H = 600
PowerTag INS-INV 100/250 (ELCB)		X = 117 m = 9m H = 450

i NSX Vigi 100/250 (ELCB)

LVS03243

180°

1
2

i NSX 100/250 + CT

LVS03241

180°

1
2

Schneider Electric Industries SAS
35, rue Joseph Monier
92506 Rueil Malmaison
France

www.se.com

04696022AH-00

En raison de l'évolution des normes et du matériel, les caractéristiques indiquées par le texte et les images de ce document ne nous engagent qu'après confirmation par nos services.

As standards, specifications and designs change from time to time, please ask for confirmation of the information given in this publication.

Publication : Schneider Electric
Réalisation :
Impression :
format de pliage : 210 x 148.5

© 2020 Schneider Electric - All rights reserved.

Ce document a été imprimé sur du papier écologique.
This document has been printed on ecological paper.

04/2020